

Cartridge:	SO20034	Cartridge Wt. New:	Approx. 59 g
OEM:	Epson	Printer:	Stylus Colour Pro, Stylus Colour Pro XL
Printhead Location:	Printer	Cartridge Type:	Sponge
Reliability:	****	Skill Level:	Average

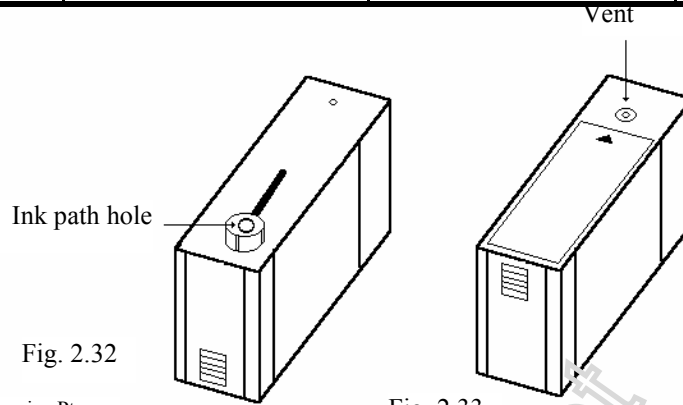

© Ausjet Ink Jet Supplies and Service Pty

Fig. 2.33

COMMENTS

With this cartridge the vacuum method of filling is easy. Read special Epson section on page 37 first.

REQUIREMENTS

- ◆ 20-30 ml Appropriate Black Ink. (Refer to Ausjet Ink Selector)
- ◆ 50 ml syringe - Do not attach a needle
- ◆ 5/32" drill
- ◆ Strong tape or Epson sealing Plugs

REFILLING METHOD

STEP 1.

Locate the ink path hole. Remove any old ink path hole tape completely, clean with alcohol and replace with fresh tape. Ensure tape is absolutely air tight. (See Fig. 2.32). Seal the air vent at the opposite end with hot glue so it is completely air tight.

STEP 2.

Locate the round indentation on the top of the cartridge **opposite** the air vent opening to the middle of the up pointing arrow and the word 'Epson'. Insert a needle into the soft centre of the indentation then enlarge the hole with the 5/32" drill tool. (See Fig. 2.33)

STEP 3.

Draw up 20 ml of ink into the 50 ml syringe. Ensure no air is drawn into the syringe. Place syringe tip firmly into the drilled air vent. Now pull syringe straight out to the 50 ml level thus forming a vacuum. If vacuum has been created correctly you will have to pull quite hard. Let go of the syringe and the negative pressure will enable the ink in the syringe to go into the cartridge by itself.

STEP 4.

Remove hot glue from vent hole. Seal injection hole with hot glue. Remove seal from ink path hole and allow to drip for 30 minutes before resealing. Use centrifugal force to charge ink path holes.